

EFB102045/9149
Deck spike
position not to scale

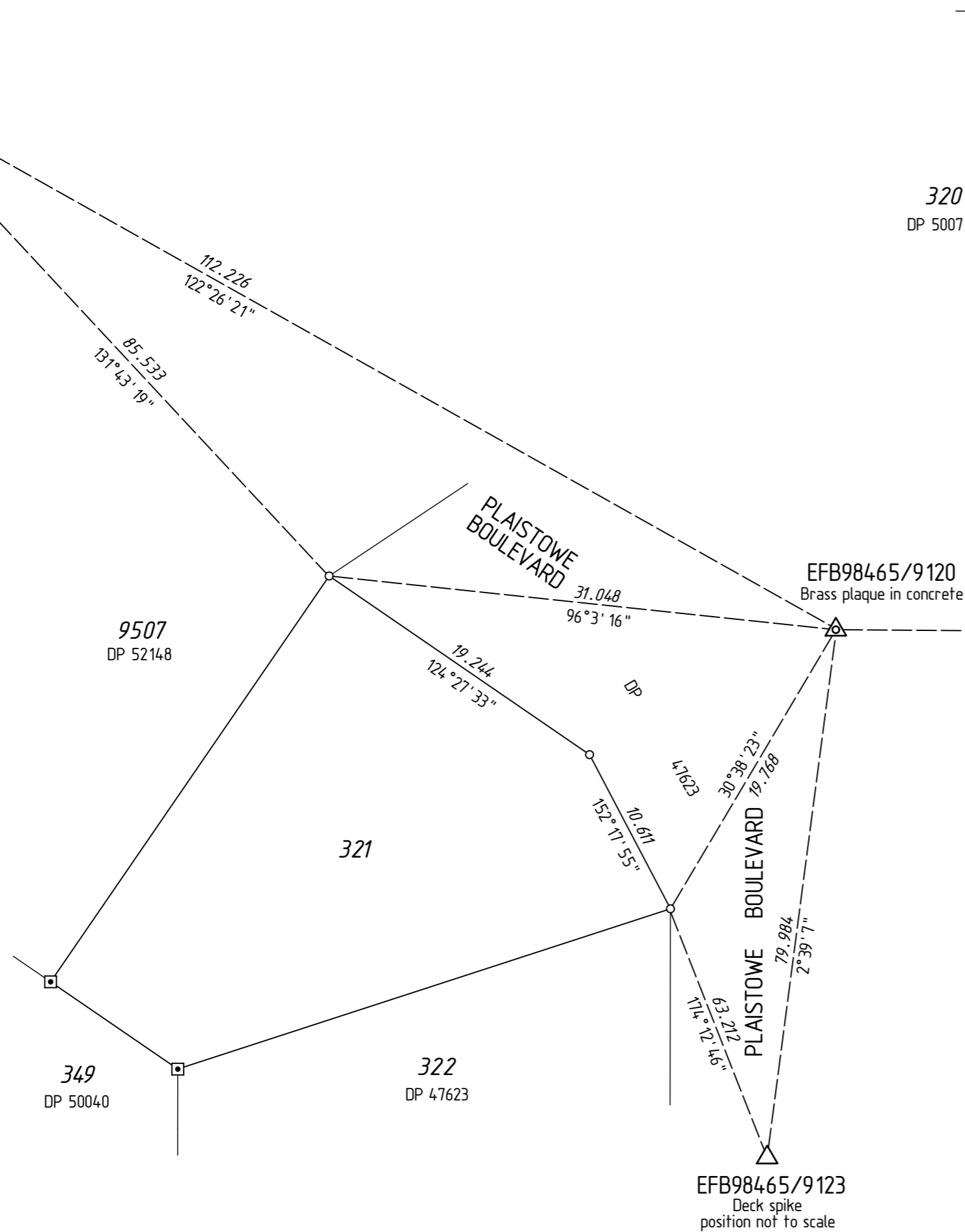

TO EFB102045/9145
Deck spike

78.618
111°49'33"

EFB102045/9144
Nail in beam

77.33
86°51'43"

TO EFB102045/9143
Deck spike

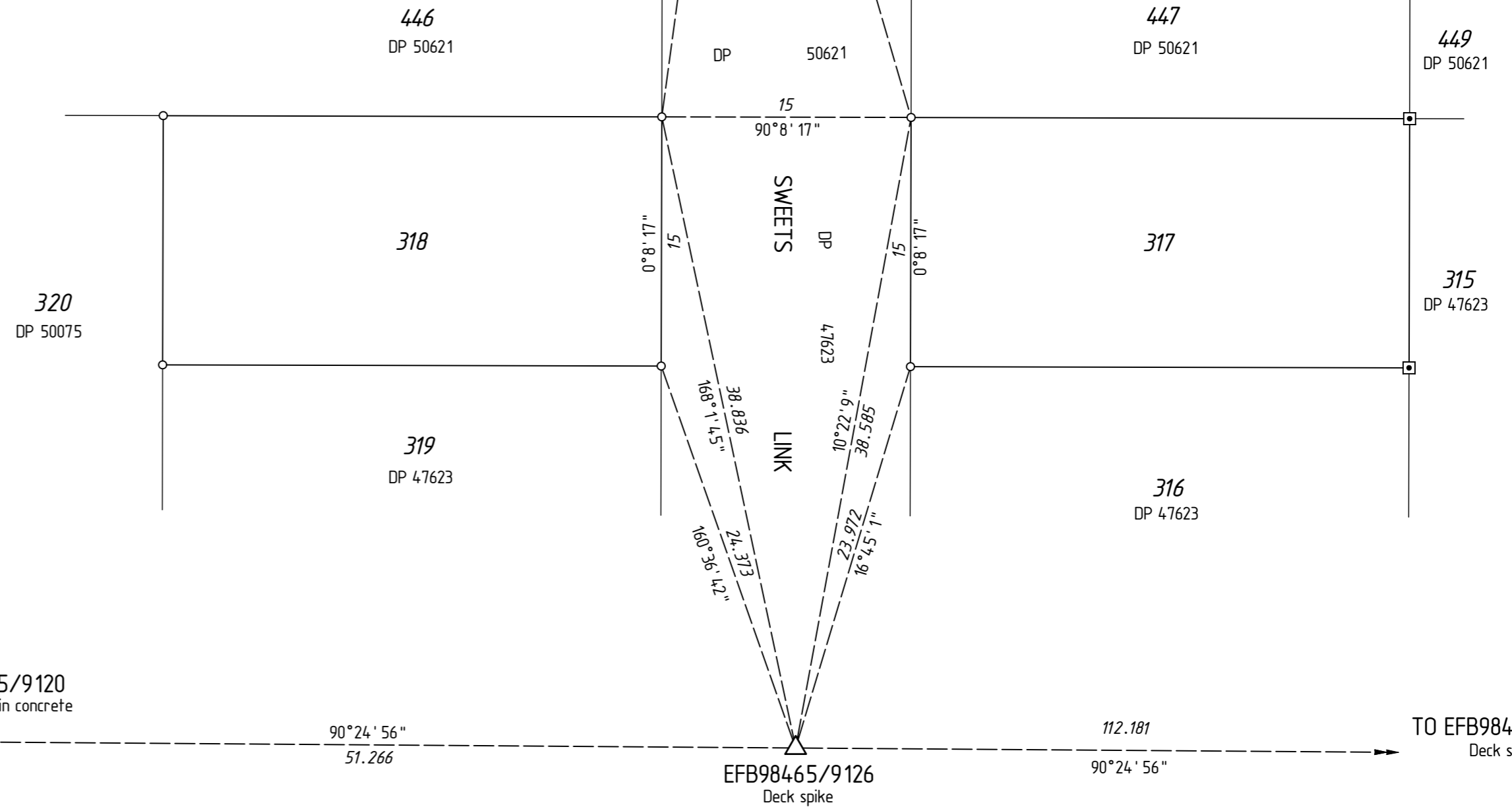

FOR INTERESTS AND NOTIFICATIONS
SEE SHEET 1

FOR HEADING SEE SHEET 1
SURVEY INFORMATION ONLY
SURVEY SHEET

SURVEY CARRIED OUT UNDER REG 26A
SPECIAL SURVEY AREA GUIDELINES

ALL BEARINGS AND DISTANCES ON THIS SHEET
ARE THE RESULT OF LEAST SQUARES ADJUSTMENTS
CARRIED OUT ON FIELD OBSERVATIONS

GRID DATUM IS PCG94

LEGEND

- Denotes Peg unless stated otherwise
- Denotes Nail
- ◻ Denotes Nail and Plate
- × Denotes Spike
- ⊗ Denotes Drill Hole
- ▲ Denotes Standard Survey Mark (SSM)
- △ Denotes Permanent Survey Mark (PSM)
- △ Denotes Permanent Control Mark (PCM)
- ⊠ Denotes Temporary Control Mark (TCM)

SCALE: 1:300
at A2
ALL DISTANCES ARE IN METRES

McMULLEN NOLAN MAPS Ref
93486dp-066d

FINAL	
Licensed Surveyor	Date
APPROVED BY WESTERN AUSTRALIAN PLANNING COMMISSION	
FILE	126085
Categorized under Sec 16 P & O Act 2005	
SHEET	2 OF 2 SHEETS
EDITION	1 VERSION 2



DEPOSITED PLAN
51262